



UNIVERSITY OF CAMBRIDGE INTERNATIONAL EXAMINATIONS
General Certificate of Education Ordinary Level

www.PapaCambridge.com

PHYSICS

5054/12

Paper 1 Multiple Choice

May/June 2012

1 hour

Additional Materials: Multiple Choice Answer Sheet
Soft clean eraser
Soft pencil (type B or HB is recommended)

* 5 9 1 0 1 7 3 4 6 7 *

READ THESE INSTRUCTIONS FIRST

Write in soft pencil.

Do not use staples, paper clips, highlighters, glue or correction fluid.

Write your name, Centre number and candidate number on the Answer Sheet in the spaces provided unless this has been done for you.

There are **forty** questions on this paper. Answer **all** questions. For each question there are four possible answers **A, B, C** and **D**.

Choose the **one** you consider correct and record your choice in **soft pencil** on the separate Answer Sheet.

Read the instructions on the Answer Sheet very carefully.

Each correct answer will score one mark. A mark will not be deducted for a wrong answer.

Any rough working should be done in this booklet.

This document consists of **16** printed pages.



- 1 A reel of copper wire is labelled 'length 30m' and 'diameter 2mm'. A student calculates the volume of the copper wire.

Which instruments does he use to measure accurately the length and the diameter of the wire?

	length	diameter
A	rule	calipers
B	rule	micrometer
C	tape	calipers
D	tape	micrometer

- 2 Which row correctly shows examples of a vector quantity and a scalar quantity?

	vector	scalar
A	area	force
B	mass	density
C	velocity	acceleration
D	weight	volume

- 3 A cyclist travels along a hilly road without using the pedals or brakes. Air resistance and friction are negligible. The speed/time graph of the cyclist is shown.

At which point did he reach the bottom of the first hill?

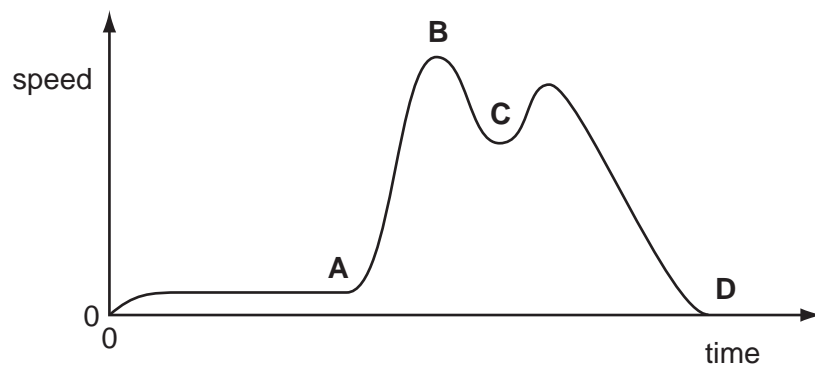

- 4 A student drops a table-tennis ball in air.

What happens to the velocity and to the acceleration of the ball during the first few seconds after release?

	velocity	acceleration
A	decreases	decreases
B	decreases	increases
C	increases	decreases
D	increases	increases

- 5 A coin falls through the air from rest, and eventually reaches a constant speed.

Two forces P and Q act on the coin.

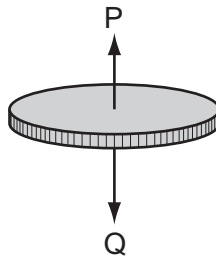

What happens to the force P and to the resultant force acting on the coin before it reaches constant speed?

	force P	resultant force
A	decreases	increases
B	decreases	decreases
C	increases	decreases
D	increases	increases

- 6 The diagram shows a motorcyclist leaning over in order to move around a corner. Which force causes him to move around the corner?

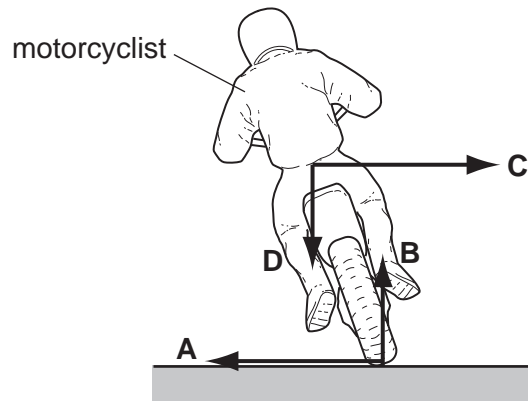

- 7 The diagram shows a uniform balanced beam, pivoted about its centre.

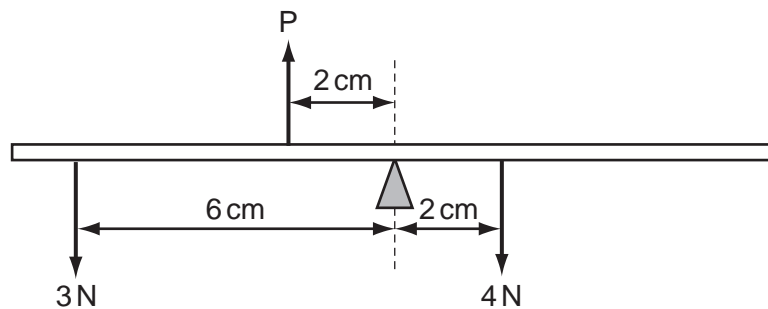

What is the value of force P?

- A 5 N B 7 N C 10 N D 13 N
- 8 The diagram shows four shapes, cut from the same piece of card.

Which shape has its centre of mass nearest to the base line?

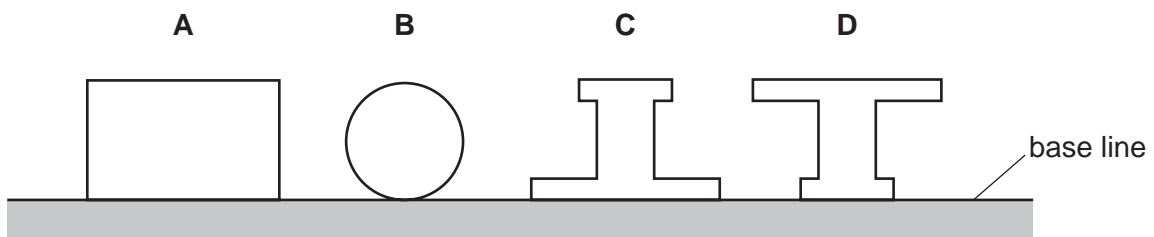

- 9 A metal wire, of initial length 1000 mm, extends by 4 mm when a load of 2 N is added to it.

What is the length of the wire when a further 3 N is added, assuming that the wire does not extend beyond the limit of proportionality?

- A 1006 mm B 1008 mm C 1010 mm D 1012 mm

- 10 The mass of a paper-clip is 0.50 g and the density of its material is 8.0 g/cm^3 . The total volume of a number of clips is 20 cm^3 .

How many paper-clips are there?

- A 80 B 160 C 240 D 320
- 11 The pressure of a gas in a cylinder is found using a water manometer.

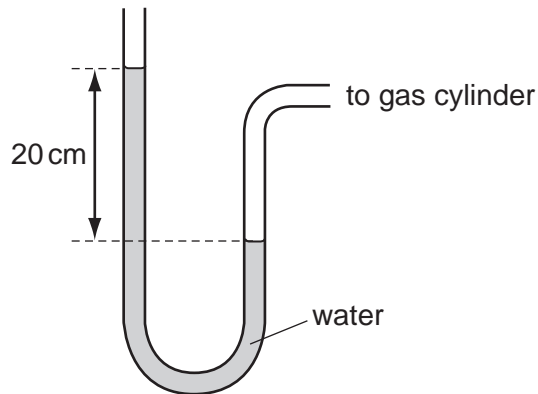

The density of water is 1000 kg/m^3 and the gravitational field strength g is 10 N/kg .

What is the pressure, above atmospheric pressure, of the gas in the cylinder?

- A 200 Pa B 2000 Pa C 20 000 Pa D 200 000 Pa
- 12 Two cylinders are connected by a thin pipe.
- One cylinder has a volume of 200 cm^3 and contains air at pressure P .
- The other cylinder has a volume of 100 cm^3 and contains a vacuum (no air).

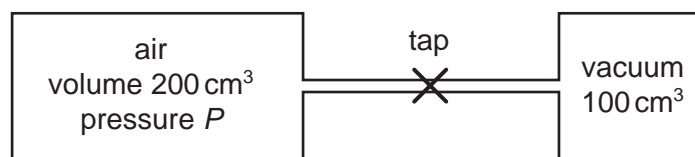

Initially, the tap is closed.

What is the final pressure of the air after the tap is opened?

- A $\frac{P}{2}$ B $\frac{2P}{3}$ C $\frac{3P}{2}$ D $2P$

- 13 Two major components of a coal-fired power station are a turbine and a generator.

What are the output forms of energy from the turbine and from the generator?

	turbine	generator
A	electrical	electrical
B	electrical	kinetic
C	heat	kinetic
D	kinetic	electrical

- 14 What is efficiency?

- A** $\frac{\text{total energy input}}{\text{useful energy output}}$
- B** $\frac{\text{total power input}}{\text{useful energy output}}$
- C** $\frac{\text{useful energy output}}{\text{total energy input}}$
- D** $\frac{\text{useful power output}}{\text{total energy input}}$

- 15 A fixed mass of gas is enclosed in a cylinder by a movable piston.

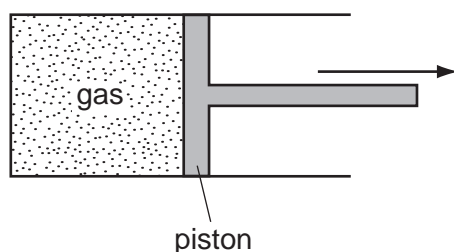

The piston is moved so that the volume occupied by the gas increases. The temperature remains constant.

What happens to the pressure of the gas and why does this happen?

	pressure	reason
A	decreases	the molecules move more slowly
B	decreases	the molecules collide with the piston less frequently
C	increases	the molecules move more quickly
D	increases	the molecules collide with the piston more frequently

16 Four wet towels are hung out to dry as shown.

Which towel dries most quickly?

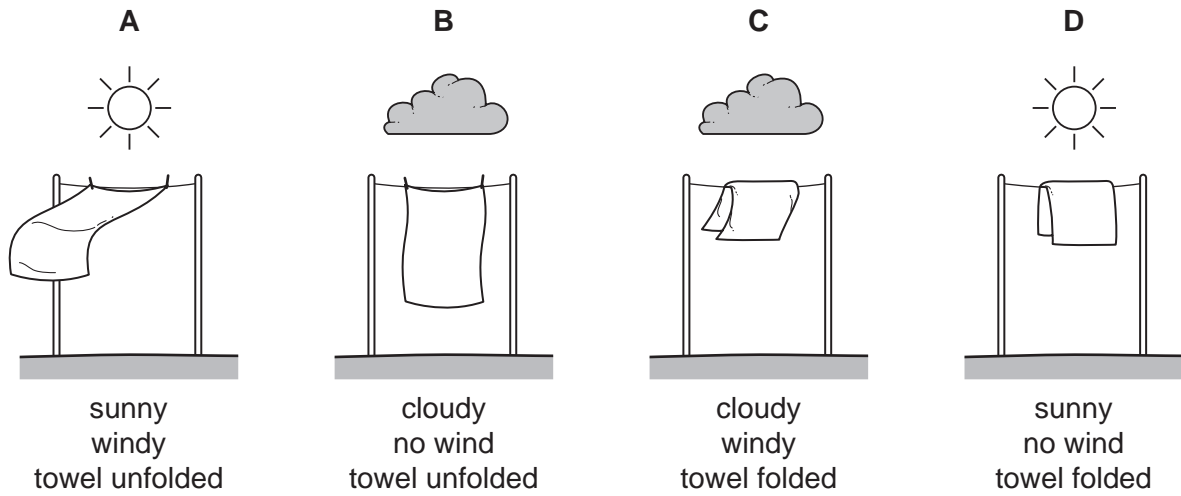

17 How is heat conducted in a metal?

- A** by movement of electrons through the metal only
- B** by movement of atoms through the metal only
- C** by vibration of atoms and movement of electrons through the metal
- D** by vibration of atoms only

18 The diagram shows four thermometers.

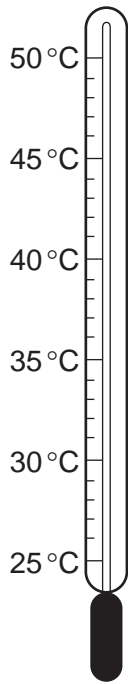

P

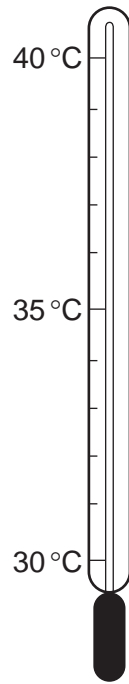

Q

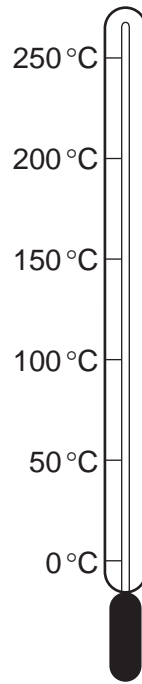

R

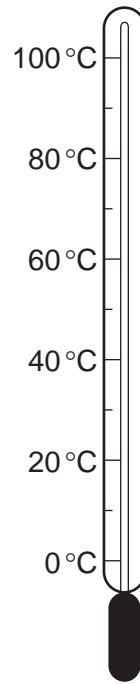

S

Which thermometer has the greatest sensitivity and which thermometer has the greatest range?

	greatest sensitivity	greatest range
A	P	R
B	P	S
C	Q	R
D	Q	S

- 19 Ice at -10°C is heated until it is water at $+10^{\circ}\text{C}$.

Which graph shows how the temperature changes with time?

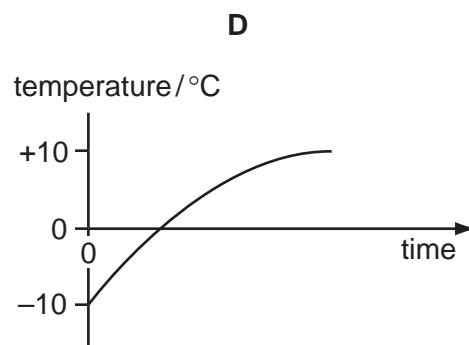
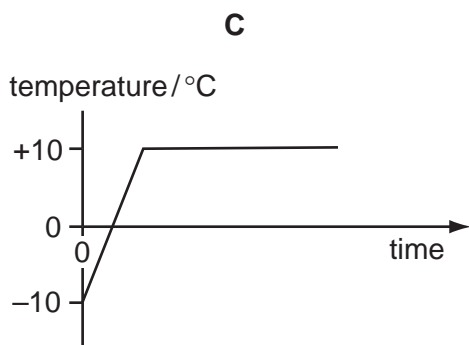
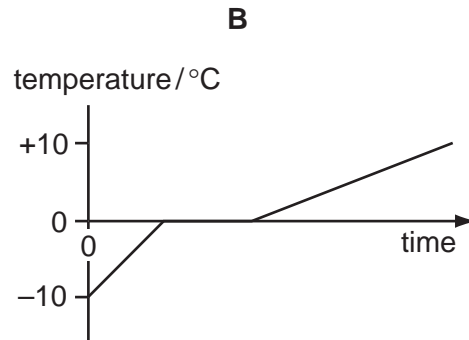
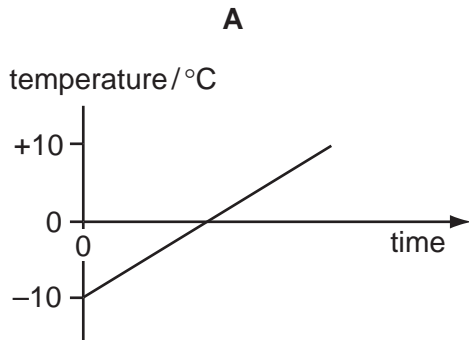

- 20 A substance has a melting point of -17°C and a boiling point of 117°C .

In which state does the substance exist at -10°C and at 110°C ?

	at -10°C	at 110°C
A	solid	liquid
B	solid	gas
C	liquid	liquid
D	liquid	gas

- 21 A wave has a frequency of 2 Hz.

How many waves are produced in one minute?

- A** 2×60 **B** $\frac{60}{2}$ **C** 2 **D** $\frac{2}{60}$

22 The diagram shows a ray of light directed at a plane mirror.

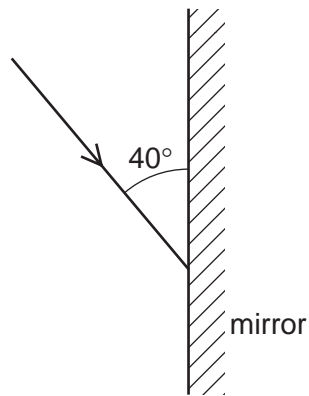

What are the angle of incidence and the angle of reflection?

	angle of incidence	angle of reflection
A	40°	40°
B	40°	50°
C	50°	40°
D	50°	50°

23 Light travels through a glass block as shown.

Which angle is the critical angle for light in the glass?

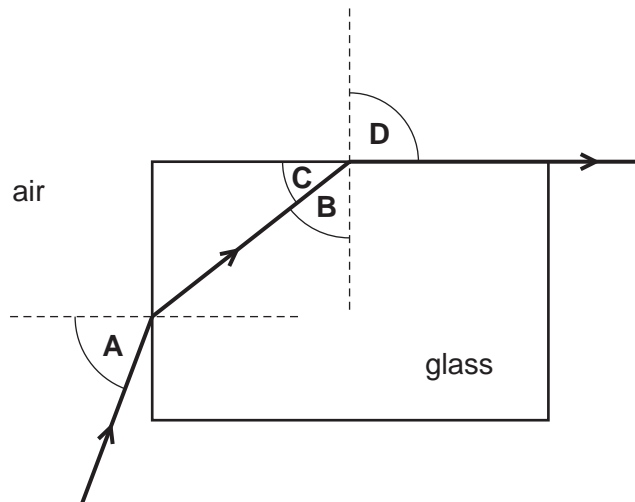

24 A man is short-sighted.

Which ray diagram shows what happens in his eye when he looks at a distant object?

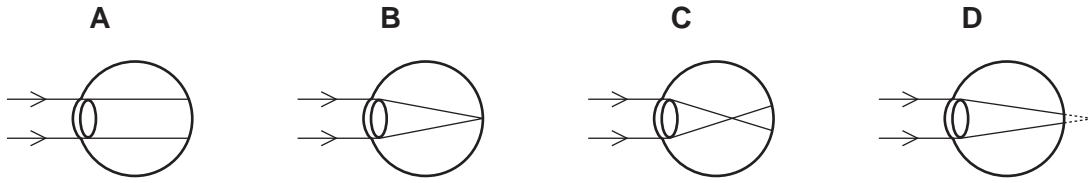

25 Which device uses ultra-violet radiation?

- A electric grill
- B intruder alarm
- C television remote controller
- D sunbed

26 Two long, straight wires hang vertically, close to each other.

The wires carry currents in opposite directions.

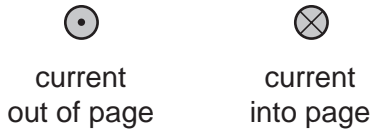

Which diagram shows the magnetic field pattern around the wires?

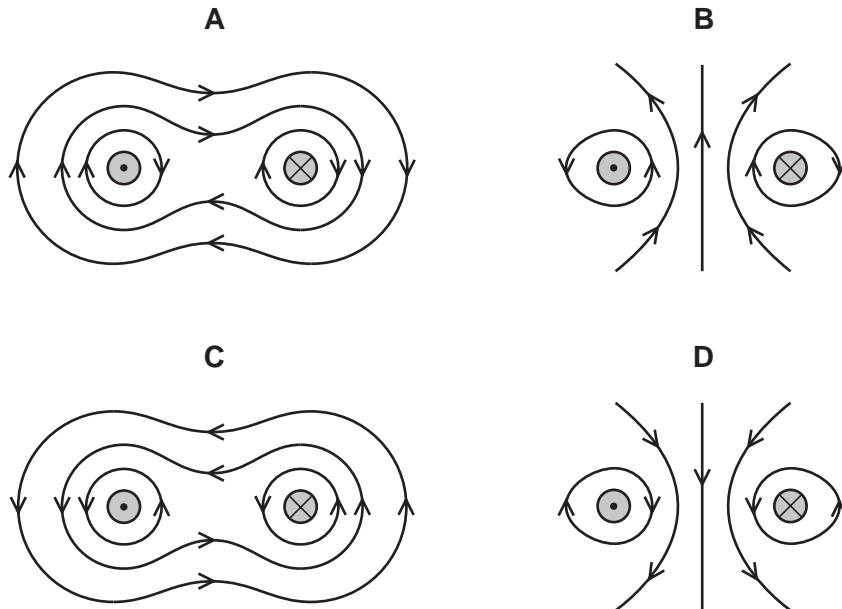

27 A positively-charged insulated metal sphere is brought close to, but does not touch, an uncharged metal sphere.

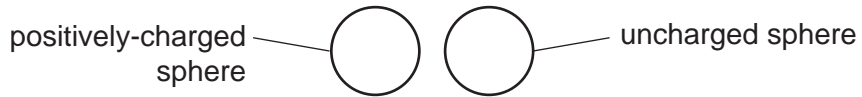

Which diagram shows the charge distribution on the spheres?

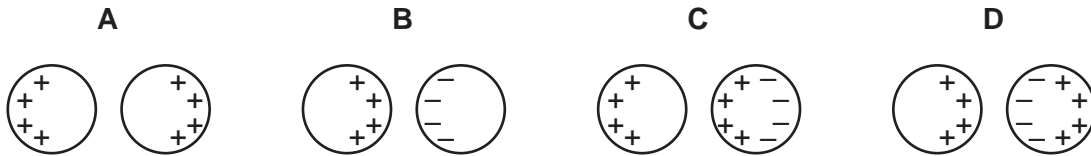

28 The current/voltage graphs are for different electrical components.

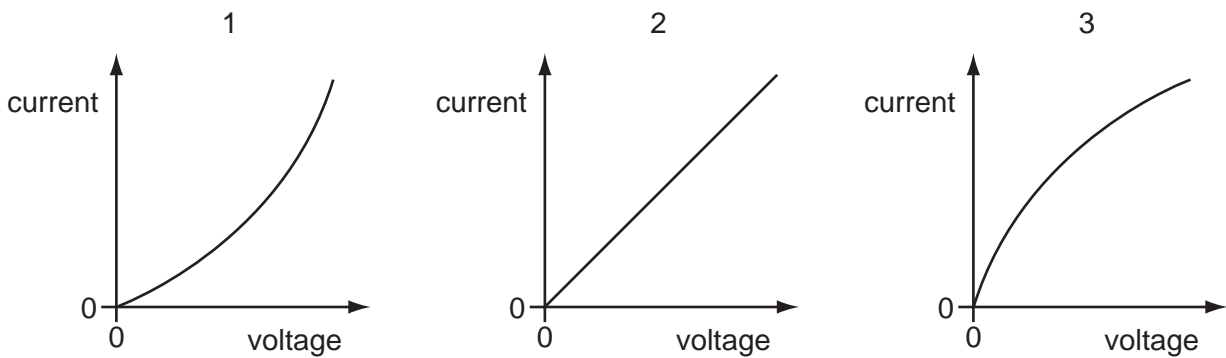

Which graph is for a resistor at constant temperature and which is for a filament lamp?

	resistor	lamp
A	1	2
B	2	1
C	2	3
D	3	2

29 The diagram shows an ammeter connected in a circuit.

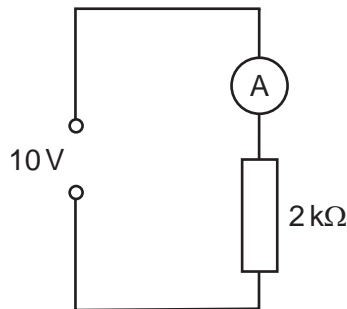

What is the current in the ammeter?

- A** 5 mA **B** 20 mA **C** 0.2 A **D** 5 A

- 30 In the circuit shown, the potential difference (p.d.) across the 4Ω resistor is 8 V.

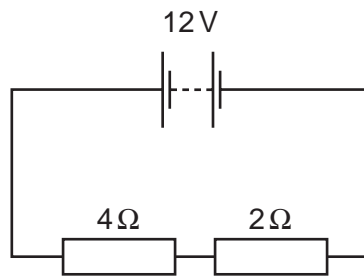

What is the p.d. across the 2Ω resistor?

- A** 4 V **B** 6 V **C** 8 V **D** 16 V
- 31 A lamp is rated at 12 V, 600 mW.
What is the current in the lamp?
- A** 20 mA **B** 50 mA **C** 2.0 A **D** 5.0 A
- 32 A water heater uses 6 kW of electric power when connected to a 240 V circuit.
Which fuse is **most** suitable for use in this circuit?
- A** 5 A **B** 13 A **C** 30 A **D** 50 A
- 33 The diagram shows a beam of electrons entering a magnetic field. The direction of the field is into the page.



In which direction are the electrons deflected?

- A** into the page
B out of the page
C towards the bottom of the page
D towards the top of the page

- 34 A rectangular coil is placed between the poles of a magnet. A current passes through it as shown.

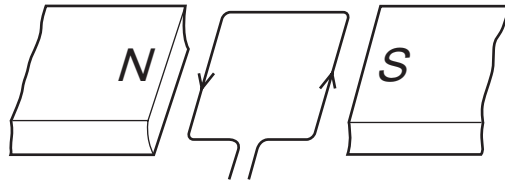

What happens to the coil?

- A It moves downwards.
 - B It moves upwards.
 - C It rotates anticlockwise.
 - D It rotates clockwise.
- 35 A bar magnet is pushed into one end of a long coil connected to a sensitive meter.

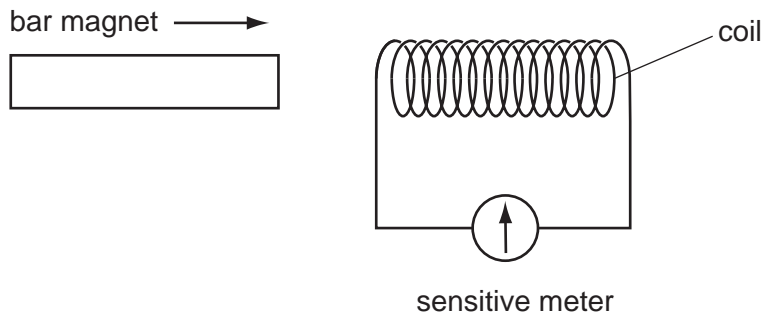

Which of the following affects the **magnitude** of the deflection of the meter?

- A the direction in which the coil is wound
- B the speed with which the magnet enters the coil
- C which end of the coil is used
- D which pole of the magnet enters first

36 Which graph represents the voltage output of a simple a.c. generator?

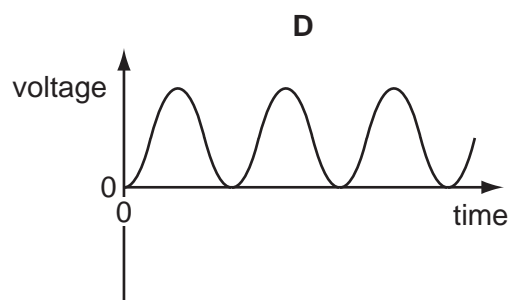
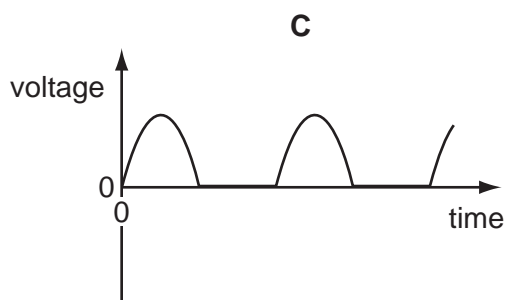
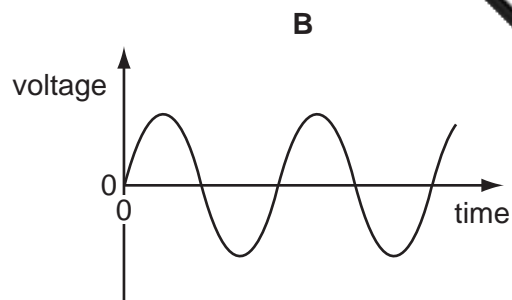
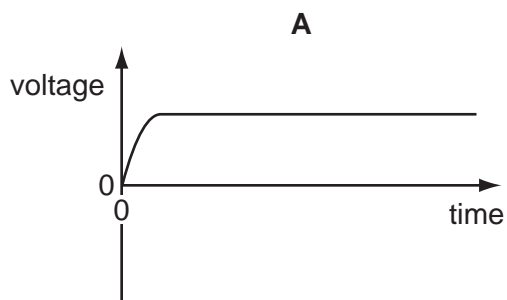

37 The electrical circuit shown consists of a cell connected to a resistor.

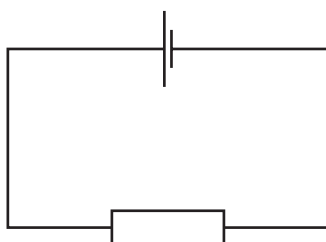

What are the directions of the electron flow and of the conventional current in the **resistor**?

	electron flow	conventional current
A	→	→
B	→	←
C	←	←
D	←	→

38 The nucleus of a helium atom is represented as ${}^4_2\text{He}$.

What does a neutral atom of helium contain?

	electrons	protons	neutrons
A	2	2	2
B	2	4	2
C	4	2	2
D	4	4	2

39 What is the safest way to dispose of a large quantity of highly radioactive waste?

- A** burning it on a fire
- B** burying it in dry rock deep underground
- C** pouring it down the drain
- D** pumping it into a river

40 The count rate from a radioactive material falls from 400 counts per second to 50 counts per second in 12 minutes.

What is its half-life?

- A** 8 minutes
- B** 6 minutes
- C** 4 minutes
- D** 3 minutes